

FEATURES

- DWDM transmitter: up to 16 wavelengths on ITU grid
- Hot plug-in/out, individually replaceable transmitter modules
- Optimized for full spectrum all QAM loading
- Manual or Automatic Gain Control (AGC) modes
- Low power consumption
- Industry's highest DWDM rack density: 48 transmitters per 3RU chassis, with redundant power supplies and optical multiplexing
- Front access -20 dB input test point
- Front panel laser On/Off control
- Local and remote status monitoring features

The CommScope HT3580H Series Quad-Density Full Spectrum Dense Wave Division Multiplexing (DWDM) Transmitter System provides high performance and a high rack density forward path transmission solution for Cable TV service providers.

The high-density packaging design allows up to eight (8) HT3580H series high performance transmitters plus a CC3008 Communications Control Module to be stacked vertically and contained by the CA3008 module carrier, requiring only two chassis slots of a 3RU chassis. The compact solution supports up to 48 transmitters in a CH3000 chassis, including redundant power supplies.



When installed in the chassis, the transmitters interface to a “zero-slot” back plate, providing support for up to eight HT3580H series transmitters. The figure below shows a fully loaded carrier mated to the BD31A8 Quad-Density back plate that supports eight HT3580H transmitters.

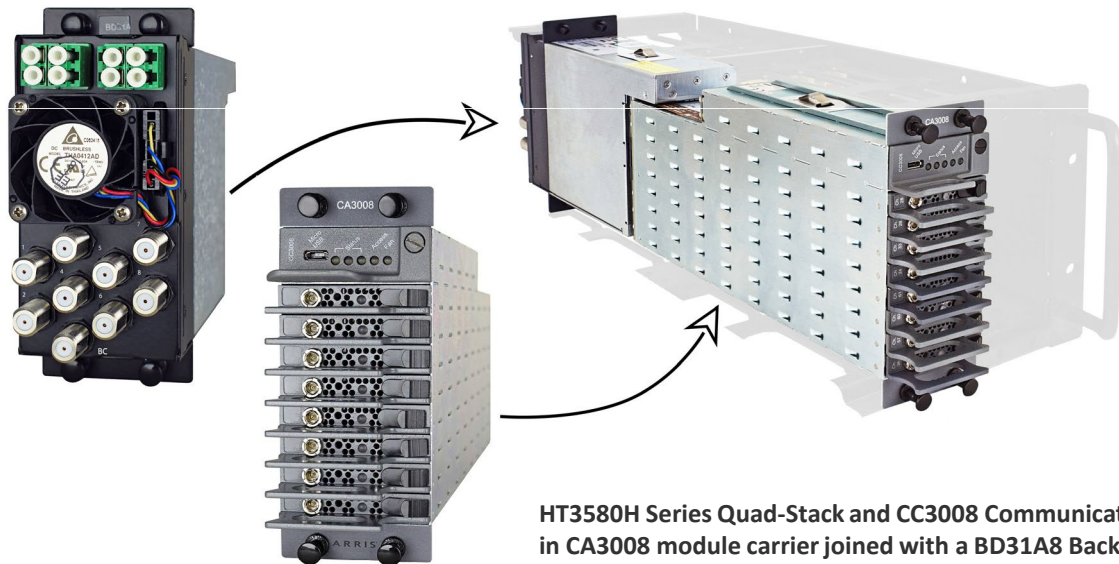

HT3580H Series Quad-Stack and CC3008 Communications Module in CA3008 module carrier joined with a BD31A8 Back Plate

The CC3008 Communications Module installed at the top of a HT3580H series transmitter stack provides the communications interface between the transmitters and the CH3000 mid-plane bus, allowing complete configuration and management control of the stack, both local and remote.

HT3580H Series Quad-Density Full Spectrum DWDM Transmitters (1.2 GHz Passband)

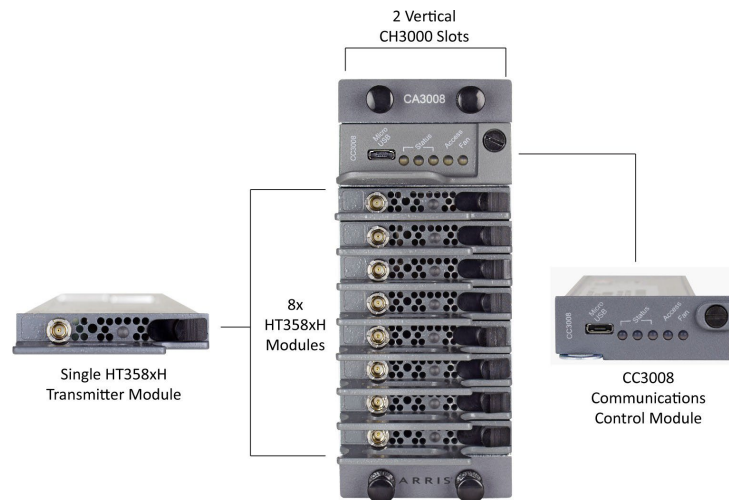

CommScope HT3580H Series Quad-Density Full Spectrum DWDM Transmitters are a key element of the CommScope HFC and Fiber Deep architectures in support of the evolution to all QAM transmission. These high-performance transmitters are designed for Dense Wave Division Multiplexing (DWDM) applications for point-to-point forward path transmission of full spectrum broadcast and narrowcast services.

HT358xH series transmitters are designed for all QAM loading. These transmitters also incorporate advanced dispersion compensation circuitry to enable transmission of high-quality signals over maximum distances.

The above figure shows a front view of the CA3008 carrier components: a single HT358xH Quad-Density Transmitter (left); a single CC3008 Communications Module (right), and a fully loaded “stack” (center) providing eight (8) DWDM transmitters, requiring only 2 slots of a CH3000 Chassis. A fully loaded CH3000 chassis supports 48 Quad-Density DWDM transmitters and redundant power supplies.

Features

- DWDM transmitter: 16 wavelengths on the ITU grid
- Manual or Automatic Gain Control (AGC) modes
- RF input attenuation up to -6 dB
- Optimized for full spectrum loading
- HT358xH: All QAM loading
- Hot plug-in/out, individually insertable
- Low power consumption
- Industry’s highest DWDM rack density: 48 transmitters per 3RU chassis, with redundant power supplies
- Front access -20 dB input test point
- Front panel laser On/Off interlock control
- Local and remote status monitoring

HT3580H SERIES SPECIFICATIONS

Characteristics	Specification
Physical	
Dimensions	11.5" D x 0.4" H x 2.0" W (29.2 x 1.0 x 5.1 cm)*
Weight	0.4 lb (0.18 kg)
	* Eight (8) transmitter units designed to be vertically stacked, plus a CC3008 Communications Module, and installed inside a CA3008 Module Carrier. The combination occupies two slots in a 3RU CH3000 Chassis.
Environmental	
Operating	-20° to +50°C (-4° to 122°F)
Storage	-40° to +85°C (-40° to +185°F)
Humidity	5% to 95% non-condensing
RF and Optical Interfaces	
RF Input	F-type male (located on BD31A8 or BD35M8 Back Plates)
RF Test Point	75Ω MCX female (located on front panel) MCX male to F female adapter provided with each Quad BD3 back plate. Additional adapters available in packs of ten, order P/N TL3MCXF-10
Optical Connector	SC/APC (located on BD35M8 Back Plates) LC/APC (located on BD31A8 Back Plates)
Power Requirements	
Input Voltage	12 VDC
Power Consumption	6 W (per transmitter) including controller and back plate cooling fan
General	
Hot plug-in/out	
Manual and automatic gain control	
Channel Loading	
	HT358xH: All QAM channels
Optical	
Optical Output Power	10 ± 0.25 dBm
Wavelength	See DWDM ITU Channel Plans description
Fiber Length	60 km max. (Dispersion Compensation adjustable in 1 km steps) • Compatible with external dispersion compensation for some applications
Electrical	
Passband	45 to 1218 MHz
Frequency Response (Including Slope)	<ul style="list-style-type: none"> ± 1.0 dB (BC input @ 25°C) ± 0.5 dB (NC input relative to BC input) NOTE: NC QAM signals are attenuated 6 dB before internal combining with BC analog signals
Nominal RF Input Levels (Input Attenuator = 0 dB)	Broadcast (BC) RF input: 10.2 dBmV 194 256-QAM channels Narrowcast (NC) RF input: 16.2 dBmV 194 256-QAM channels
RF Input Impedance	75 Ω, nom
RF Input Return Loss	18 dB, min
RF Input Attenuator/Amplify Range (Manual Mode)	-6.0 to 0 dB
RF Input Attenuator Step Size	0.5 dB
AGC Mode	Maintains RF power constant when input RF power changes up to ± 3 dB of the learned RF value
Level Stability (Typical)	± 0.2 dB
256-QAM BER	< 10 ⁻⁶ (pre-FEC, ITU-C)
MER (194 QAM load)	40 (40 km), 37 (60 km)
DWDM ITU Channel Plans	
	See muxing back plate information for wavelength graphics. CommScope supports DWDM network architectures with a variety of products on the standard DWDM ITU Grid (ITU-T G.694.1). For a more complete description, please refer to the CommScope DWDM ITU Grid Channel Plan data sheet.

BD31A8-100 Quad-Density Back Plates

The BD31A8 models provide RF input and optical connections to or from the HT358xH transmitters. The fan provides air flow to keep transmitters cool.

BD31A8-100-H10F-0-AL is a quad-density back plate that provides 1 common BC input and 8 separate NC RF inputs for eight HT358xH Transmitters. It also supports eight separate optical output LC/APC connectors. Internally it includes an RF amplifier and splitter to split the BC input equally to all 8 transmitters and maintain 1x8 RF levels.

BD31A8-100-H18F-0-AL is a quad-density back plate that provides 8 separate BC inputs and 0 NC RF input for eight HT358xH Transmitters. It also supports eight separate optical output LC/APC connectors. This back plate is recommended for customers that prefer to do their broadcast and narrowcast RF combining external from the CH3000 Chassis.



BD31A8-100-H10F-0-AL Back Plate



CA3008 Module Carrier

BD31A8 BACK PLATE SPECIFICATIONS

Characteristics	Specification
Physical	
Dimensions	7.2" D x 5.2" H x 2.0" W (18.2 x 13.0 x 5.4 cm)
Weight	2.0 lb (0.91 kg)
Environmental	
Operating	-20° to +65°C (-4° to 149°F)
Storage	-40° to +85°C (-40° to +185°F)
Humidity	5% to 95% non-condensing
Power Requirements	
Input Voltage	12 V _{DC}
Power Consumption	5.5 W max (2.5 W Typ), included in power figure found in HT3580H specifications
Optical	
Through 8 LC/APC connectors, the BD31A8-100 provides optical pass-through from the HT358xH transmitter.	
Optical Insertion Loss	0.2 dB Typ; 0.3 dB Max
RF Interface	
The BD31A8 provides RF to the HT358xH transmitter through F-type RF connectors.	<ul style="list-style-type: none"> • 1 BC and 8 NC (BD31A8-100-H10F-0-AL) • 8 BC and 0 NC (BD31A8-100-H18F-0-AL)

BD35M8-ACx and BD35M8-EEx Quad-Density Back Plates for Groups of 8 Wavelengths

The CommScope BD35M8 Family of back plates are 100 GHz grid spacing Quad-Density Mux Back Plates that multiplex the output of eight HT3580H Quad-Density Full Spectrum Transmitters.

These back plates provide connections for a group of eight HT3580H Series Transmitters installed in the same CA3008 Module Carrier, along with the CC3008 Communications Control Module.

These 8-channel mux back plates (for which outputs can be cascaded from one back plate to another) may be ordered for the channel groups indicated in the ordering information section.

BD35M8 BACK PLATE SPECIFICATIONS

Characteristics	Specification	
Physical		
Dimensions	7.2" D x 5.2" H x 2.0" W (18.2 x 13.0 x 5.4 cm)	
Weight	2.0 lb (0.91 kg)	
Environmental		
Operating	-20° to +65°C (-4° to 149°F)	
Storage	-40° to +85°C (-40° to +185°F)	
Humidity	5% to 95% non-condensing	
Power Requirements		
Input Voltage	12 V _{DC}	
Power Consumption	5 W max (2.5 W Typ), included in power figure found in HT3580H specifications	
Optical Interface		
Optical Connectors	SC/APC (3)	
	<ul style="list-style-type: none"> DWDM INP (input from previous mux back plate) DWDM OUT (output to network or next mux back plate) -20 dB optical test point 	
RF Interface		
9 F-Type Connectors	<ul style="list-style-type: none"> 1 BC and 8 NC 	
Optical		
Channel Spacing	100 GHz	
Channel Plan	See ITU Channels in Ordering Information	
Insertion Losses, Including Connectors	Typ	Max
<ul style="list-style-type: none"> DWDM Input to DWDM Output 	1.8 dB	2.1 dB
<ul style="list-style-type: none"> Ch. yy Input to DWDM Output 	2.0 dB	2.4 dB
<ul style="list-style-type: none"> -20 dB Test Point 	20.0 dB	20.4 dB
Uniformity, Including Connectors		
<ul style="list-style-type: none"> Module Uniformity 	1.1 dB	1.5 dB
<ul style="list-style-type: none"> Paired Uniformity 	0.5 dB	0.7 dB
Return Loss, min	45 dB	
Directivity, min	55 dB	
Passband @ 0.2 dB		
<ul style="list-style-type: none"> Ch. yy Input to DWDM Output 	± 0.125 nm	
<ul style="list-style-type: none"> DWDM Input to DWDM Output 	Passes 1423.5 through 1617.5 with a notch at the channel add/drop band. WDL for the passband is within ± 0.15 dB	
Polarization Dependent Loss, max	0.15 dB (typically < 0.05 dB)	
Power Handling, max (Any Input Port)	21.8 dBm	

BD35M8-DCx Quad-Density Back Plates for 2 Sets for the Same Group of 4 Wavelengths

The CommScope BD35M8 Family of back plates are 100 GHz grid spacing Quad-Density Mux Back Plates that multiplex the output of 2 sets of four HT3580H Quad-Density Full Spectrum Transmitters onto two separate output ports.

These back plates allow 2 sets of four HT3580H Series Transmitters installed in the same CA3008 Module Carrier, and using the same CC3008 Communications Control Module, to feed two different fibers with four wavelengths on each fiber.

These 2x4-channel mux back plates (for which outputs can be cascaded from one back plate to another) that may be ordered for the channel groups indicated in the ordering information section.

BD35M8 BACK PLATE SPECIFICATIONS

Characteristics	Specification	
Physical		
Dimensions	7.2" D x 5.2" H x 2.0" W (18.2 x 13.0 x 5.4 cm)	
Weight	2.0 lb (0.91 kg)	
Environmental		
Operating	-20° to +65°C (-4° to 149°F)	
Storage	-40° to +85°C (-40° to +185°F)	
Humidity	5% to 95% non-condensing	
Power Requirements		
Input Voltage	12 V _{DC}	
Power Consumption	5 W max (2.5 W Typ), included in power figure found in HT3580H specifications	
Optical Interface		
Optical Connectors	LC/APC (6)	
	<ul style="list-style-type: none"> • 2 of DWDM INP (input from previous mux back plate) • 2 of DWDM OUT (output to network or next mux back plate) • 2 of -20 dB optical test point 	
RF Interface		
9 F-Type Connectors	<ul style="list-style-type: none"> • 1 BC and 8 NC 	
Optical		
Channel Spacing	100 GHz	
Channel Plan	See ITU Channels in Ordering Information	
Insertion Losses, Including Connectors	Typ	Max
• DWDM Input to DWDM Output	1.1 dB	1.3 dB
• Ch. yy Input to DWDM Output	1.3 dB	1.5 dB
• -20 dB Test Point	20.0 dB	20.4 dB
Uniformity, Including Connectors		
• Module Uniformity	0.4 dB	0.5 dB
• Paired Uniformity	0.5 dB	0.7 dB
Return Loss, min	45 dB	
Directivity, min	55 dB	
Passband @ 0.2 dB		
• Ch. yy Input to DWDM Output	± 0.125 nm	
• DWDM Input to DWDM Output	Passes 1423.5 through 1617.5 with a notch at the channel add/drop band. WDL for the passband is within ± 0.15 dB	
Polarization Dependent Loss, max	0.1 dB (typically < 0.05 dB)	
Power Handling, max (Any Input Port)	21.8 dBm	

ORDERING INFORMATION

HT358xH Transmitter

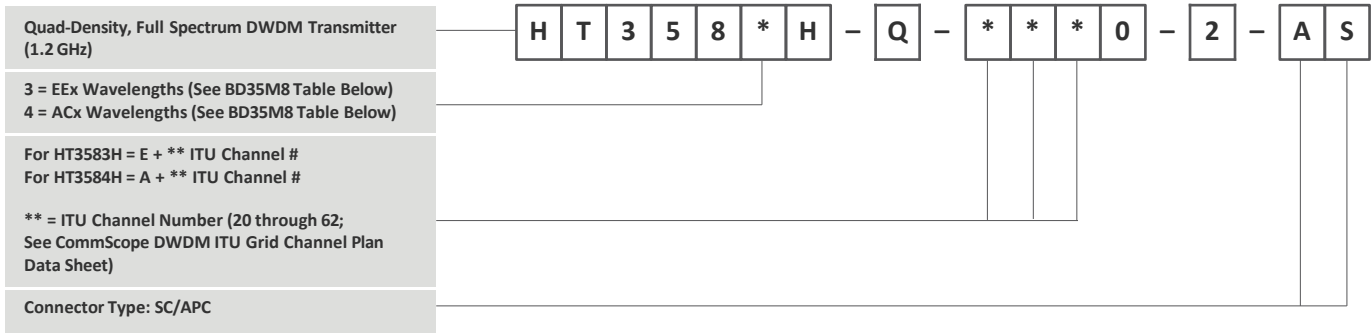

Back Plates

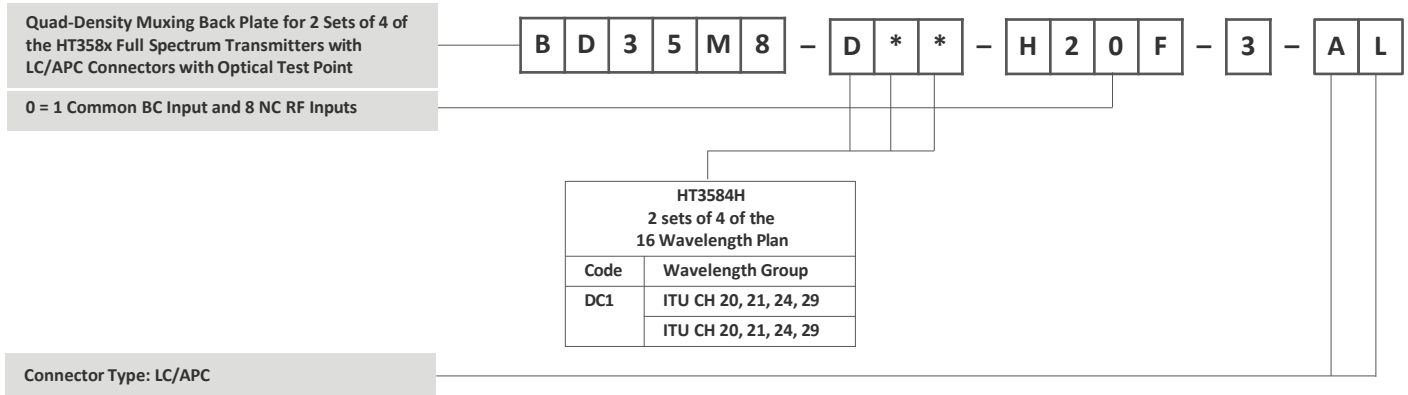
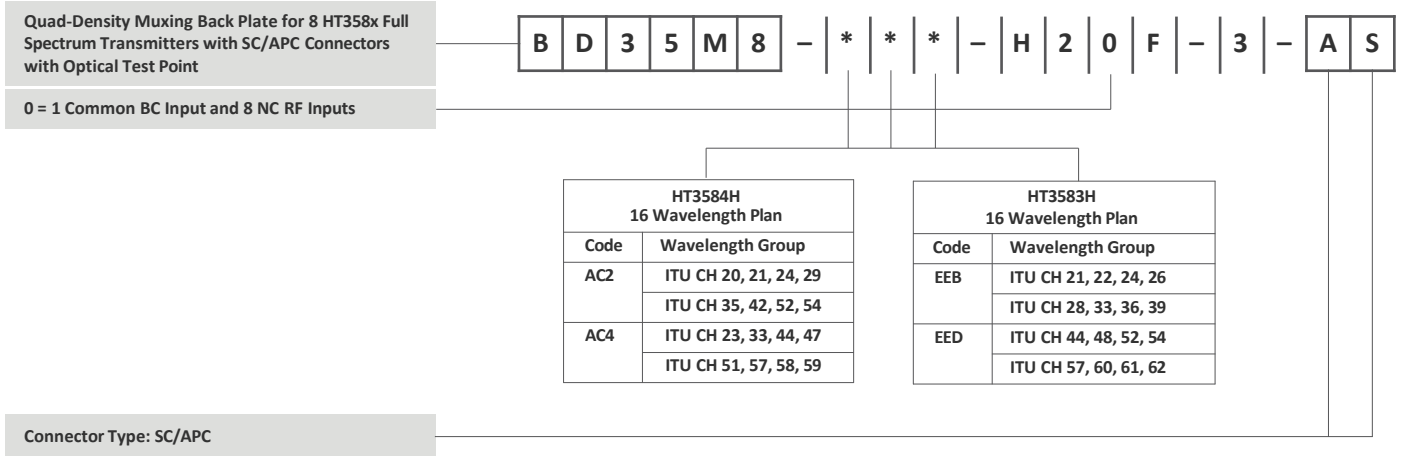
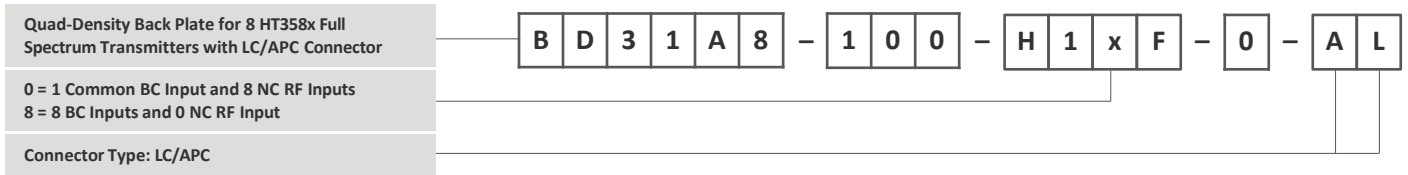

ORDERING INFORMATION

System Accessories

Communications Control Module

C C 3 0 0 8

Module Carrier

C A 3 0 0 8

Filler Module for Quad-Density Slots

H T 3 F I L H



RELATED PRODUCTS

CH3000 Chassis	Optical Patch Cords
Optical Transmitters	Optical Passives
Digital Return	Installation Services



Note: Specifications are subject to change without notice.

Copyright Statement: © 2022 CommScope, Inc. All rights reserved. ARRIS and the ARRIS logo are trademarks of CommScope, Inc. and/or its affiliates. All other trademarks are the property of their respective owners. No part of this content may be reproduced in any form or by any means or used to make any derivative work (such as translation, transformation, or adaptation) without written permission from CommScope, Inc and/or its affiliates ("CommScope"). CommScope reserves the right to revise or change this content from time to time without obligation on the part of CommScope to provide notification of such revision or change.

1511670_HT3580H_Double-Density-Transmitter-System_Rev F