



advanced media technologies®



PRODUCT SOLUTIONS

MODEL

# GENACIS QS III

ComSonics, an employee owned company, is the global leader in proactive plant maintenance, providing solutions to ensure HFC plant integrity and performance improvement.

The Genacis QS III is a high performance platform used for automated leakage detection for vehicle applications. The new Genacis QS III now has triple frequency detection with frequency agility to ensure complete spectrum coverage for both digital QAMs and D3.1 OFDM signaling. In addition, the new GQS III also provides simultaneous LTE downlink power measurements.

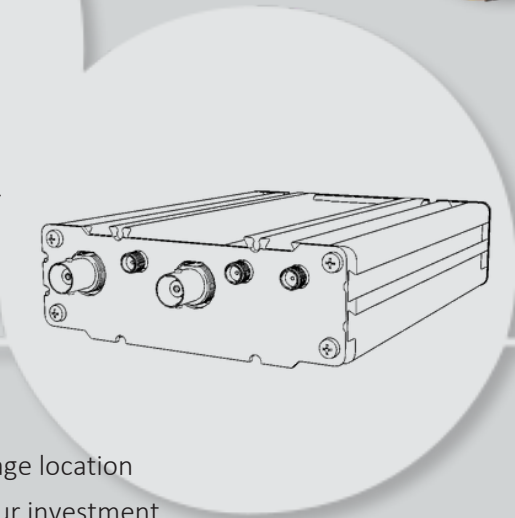
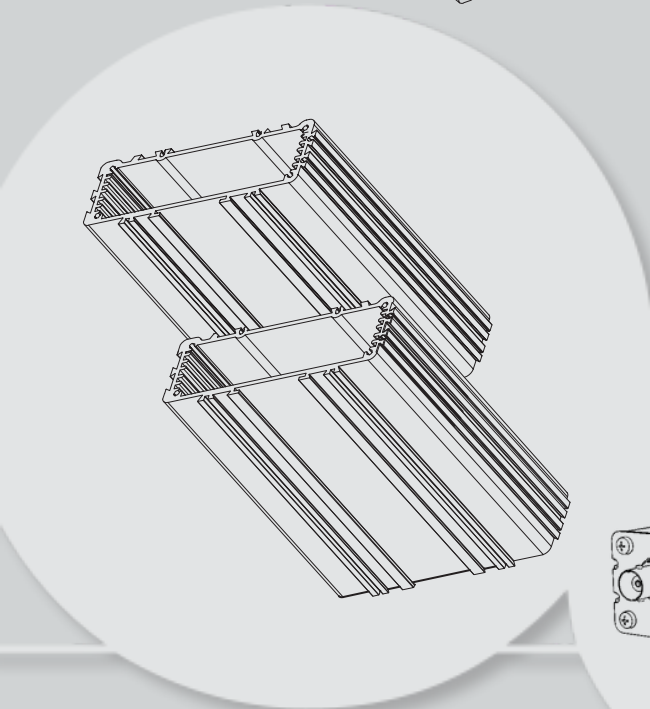
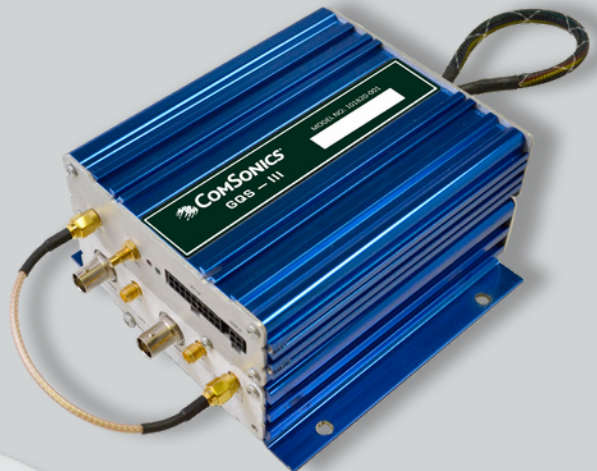
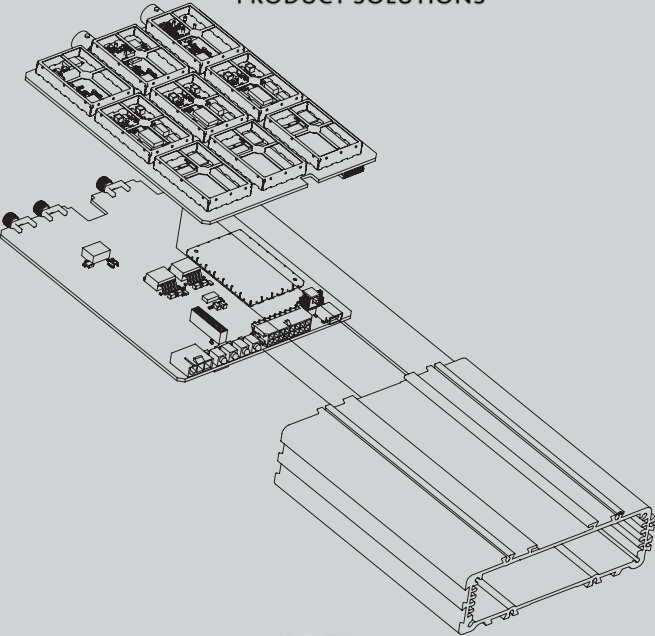

- High accuracy GPS for superior leakage location
- DOCSIS 3.1 ready to future proof your investment
- Bluetooth connectivity for mobile applications
- such as MPL LTE downlink power measurements





## Specifications

### Genacis™ QS RF Modules

RF Input Impedance	50 ohms
Tuning Frequency	USA B1: 136.5 – 138.5 MHz USA B2: 610 – 612.5 MHz USA B3: 770 – 860 MHz, 900 MHz – 1.2 GHz  Int'l B1: 132.5 – 140 MHz Int'l B1: 259.0 – 271.0 MHz <i>Option</i> Int'l B2: 606.5 – 614.5 MHz Int'l B3: 824 – 915 MHz, 970 MHz – 1.2 GHz
LTE Downlink Power Measurement	USA: 728 MHz – 768 MHz Int'l: 791 MHz – 821 MHz
Receiver Sensitivity	130 MHz to 600 MHz -105 dBmV 600 MHz to 1.2 GHz -100 dBmV
Selectivity	5Hz
Measurement Accuracy	< ± 2.0 dB
GPS Sampling	5 per second
External Power	12 V Nominal
Operating Temperature	0°F to 120°F (-18°C to 49°C)
Storage Temperature	-20°F to 150°F (-29°C to 66°C)

## Features

### Genacis™ QS RF Module

- Works in 100% digital and mixed analog systems
- Three frequencies with agility in band 3
- Eliminates false leakage detection
- One box design contains all three frequencies
- Simultaneous LTE downlink power measurements
- Bluetooth connectivity
- Hands free and silent operation
- Near real time data via cellular connection
- GPS reference clock for high accuracy measurements

### Genacis™ HUB

- Fully integrated GPS and cellular hub
- Supports boom truck position detection
- Stackable modular box design with RF module

### D3.1 OFDM Leakage Detection per

### Band RPD Compatibility

- Works with RPD systems that are compliant ComSonics' specifications

### Genacis™ HUB

External Power	12 V Nominal
Operating Temperature	-40°F to 140°F (-40°C to 60°C)

## ComSonics also offers:



QAM Marker



QAM Shadow



QAM Sniffer III



QAM Compass



M3 — Mini Mobile Marker