

**1.22 GHz MULTIMEDIA HOME PHONE PORT
 SUBSCRIBER AMPLIFIERS**

**LINDSAY
 BROADBAND**

Provide uninterrupted lifeline service with this unity gain, forward/reverse multimedia amplifier that incorporates a stand-alone passive home phone port.

Power outages can take down vital voice and data signals. The Lindsay Broadband reverse-active subscriber amplifier (LRSA) avoids that outcome by incorporating a completely standalone passive home phone port to route all voice and data signals. Available in five- or nine-port design. The compact, environmentally hardened amplifier features upstream and downstream unity gain and power insertion options on home phone and video ports. Preassembled network interface unit (NIU) and uninterruptible power supply (UPS) options also available.



BLOCK DIAGRAM

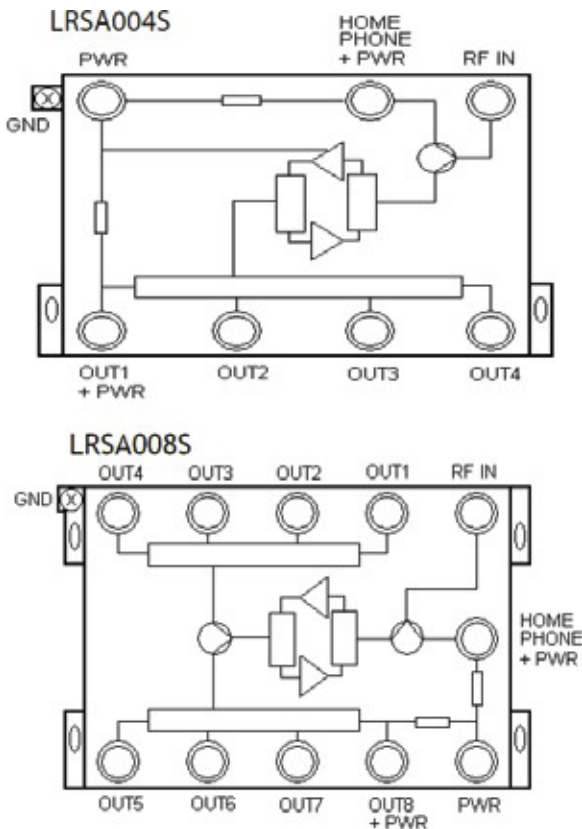

FEATURES

- Industry's smallest footprint
- Corrosion-resistant epoxy-coated 360 aluminum
- 15 PSI pressure tested
- Passive home phone port
- Five or Nine RF outputs
- Upstream and downstream unity gain
- SCTE-compliant F-Port
- SCTE-compliant surge withstand
- SS ground and mounting hardware
- Power pack short-circuit protection, UL listed
- Powered by 120 or 220 voltage AC wall adapter
- Power LED Indicator
- Optional preassembled NIU's
- Diplex Filters available in 42/54 and 85/102 MHz
- Power insertion available on phone, video ports

*Optional power inserter
 part # 15-100*



SPECIFICATIONS

Unity Forward & Reverse Gain
Multimedia Amplifiers
Splitter Bypass

		4 RF Output + 1 Home Phone		8 RF Output + 1 Home Phone		
		LRSA004S		LRSA008S		
Parameter		Typical	Worst	Typical	Worst	
Forward Path 54-1220 MHz or 102-1220 MHz						
Gain (active output ports)	(54/102-1000 MHz) (1000-1220 MHz)	0	-1	0	-1	dB
Gain Tolerance	(54/102-1220 MHz)	± 0.5		± 0.5		
Flatness	(54/102-1000 MHz)	± 0.5	± 0.75	± 0.5	± 0.75	dB
	(1000-1220 MHz)	± 0.75	± 1.0	± 0.75	± 1.0	
Maximum Input Level	(54/102-1220 MHz)	14		14		dBmV
Insertion Loss (passive port)	< 1000 MHz	3.5 ± 0.5		3.5 ± 0.5		dB
	1000 - 1220 MHz	5		5		
CTB		-75	-70	-75	-70	dBc
CSO		-65	-62	-65	-62	
Noise Figure	(54/102-1220 MHz)	5		5		dB
Group Delay	any channel	20		20		ns
Return Path 5-42MHz or 5-85 MHz						
Gain (active output ports)	(5-42/85 MHz)	0		0		dB
Gain Tolerance	(5-42/85 MHz)	± 1		± 1		
Insertion Loss (passive port)		3.5 ± 0.5		3.5 ± 0.5		dB
Flatness	(5-42/85 MHz)	± 0.5	± 0.75	± 0.5	± 0.75	
DSO		-70	-65	-70	-65	dBc
DTO		-60	-57	-60	-57	
Noise Figure	(5-42/85 MHz)	5	6	5	6	dB
Group Delay	(5-42/85 MHz)	20		20		ns
General Specifications 5-42/85 MHz, 54/102-1220 MHz						
Impedance		75				Ohm
Return Loss	(5-42/85 & 54/102-1220)	20	18	20	18	dB
	(5-42/85 & 54/102-1220)	20	18	20	18	
Isolation	(5-42/85 & 54/102-1000)	25	24	25	24	dB
	1000 - 1220 MHz	24	22	24	22	
Hum Modulation	(5-42/85 / 54/102-1220)		-70		-70	dBc
Power Supply Noise		-50/-80/-100				dBm
Unterminated Oscillation		NONE				
RFI	(54/102-1220)	-100				dBc
CE Compliance	ROHS					
	WEEE					
	EMC					
	LVD					
Surge Withstand Capability		6kV 3kA, 8/20us Combo Wave IEEE 587 (C62.41-1991) Category B3 Standard				
		6kV 200A, 0.5-100KHz, Ring Wave IEEE 587 (C62.41-1991) Category A3 Standard				
Operating Temperature		-40 to +60				°C
DC Power Consumption		330		370		mA
Port Diode Protection		yes				
Waterproof		Withstand 15 psi for 1 minute				

Note:

- (1) 14dBmV/ch flat input level (75 NTSC) + digital at 6dB setback (after 550 MHz)
- (2) As per SCTE115, 13&19MHz channels at 55 dBmV/ch output, w/c of DSO at 6/32MHz and DTO at 7/25MHz
- (3) Max for (DC-500kHz) / (500kHz-1.5MHz) / (1.5MHz-1.2GHz). Measure at RF OUT while using power inserter
- (4) No oscillations should occur with IN and OUT ports terminated and unterminated
- (5) Noise Figure is specified with splitter losses excluded.

*Specifications subject to change without prior notice. Copyright © 2017 Lindsay Broadband Inc

