

P-XGS-PON-ONT



P-XGS-PON-ONT

The Positron P-XGS-PON-ONT (SFP+ form factor) is the ideal companion to the Positron G.hn Access Multiplexer (GAM) family. It adds native XGS-PON capability to the GAM devices with comprehensive OMCI support of leading OLT vendors platforms for seamless flow-through provisioning from the BSS to the OLT and ultimately to the subscriber exactly the same as with any other ONT device.

The ONT offers comprehensive OMCI extensions to allow seamless management of subscribers (VLAN, bandwidth profile) and GAM (firmware and configuration) from the existing BSS and OSS platforms without extra IT integration efforts.

The P-XGS-PON-ONT is fully compliant with the ITU-T G.9807.1 with 9.95 Gbps in both directions: continuous mode downstream and burst-mode upstream. It is packaged as a SFP+ (Small Form-factor Pluggable) with an XFI interface. It offers advanced data features such as VLAN tag manipulation (Q-in-Q), QoS, classification and filtering to complement the GAM capabilities.

The P-XGS-PON-ONT provides digital diagnostic information of its operating conditions and status including module temperature, transmitter and receiver optical power and supply voltage as per SFF-8472 and ITU-T G.9807.1 recommendations.

Feature	P-XGS-PON-ONT
ITU-T Standard	XGS-PON -- G9807.1 Class N1
OMCI	As per ITU-T G.988
Firmware Management	Via OMCI download
Operating Temperature	-45°C to +70°C
Optical Connector	SC/APC
Launch Power	4 ~ +9 dBm
Sensitivity	-29.0 dBm with BER ≤ 1 x 10 ⁻³
Distance	20 km
Wavelength	US: 1260-1280 nm DS: 1575-1580 nm
Quality of service (QoS)	Flexible mapping of XGEM ports to T-CONT with queue-based priority scheduling with 802.1p mappings

Absolute Maximum Ratings

Parameter	Symbol	Min	Max	Unit	Note
Storage Ambient Temperature	T _{STG}	-40	+85	°C	
Operating Voltage	V _{CC33}	-	3.6	V	
Operating Relative Humidity	R _H	5	95	%	

Recommended Operating Conditions

Parameter	Symbol	Min	Typ	Max	Unit	Note
Case Operating Temperature	T _{CASE}	-45	-	70	°C	1
Module Supply Voltage	V _{CC33}	3.15	3.3	3.6	V	2
Current Consumption	ICC ₃₃	-	1	-	A	
Peak Current Consumption	ICC _{33Peak}	-	1.8	2.5	A	3

Transmitter Electrical Characteristics

Parameter	Min	Typ	Max	Unit	Note
TX Differential Input Impedance	90	100	110	Ω	1
10Gb/s Tx Differential Input Amplitude	120	-	900	mV	
BEN = HIGH (Transmitter OFF / DISABLED)	2	-	V _{CC33}	V	
BEN = LOW (Transmitter ON / ENABLED)	0	-	0.8	V	

Receiver Electrical Characteristics

Parameter	Min	Typ	Max	Unit	Note
Rx Differential Output Impedance	90	100	110	Ω	1
10Gb/s Rx_Data Differential Output Voltage Amplitude (CML)	250	440	800	mV	
Rx_LOS = HIGH (Receiver OFF)	2	-	V _{CC33}	V	
Rx_LOS = LOW (Receiver ON)	0	-	0.5	V	

Note 1: SFP module must be in direct contact (mechanically attached) to the SFP Cage for correct heat dissipation.

Note 2: Inductor/Ferrite bead for host filtering must be carefully chosen, with low DCR. Module supply voltage should always be above the minimum specified.

Note 3: Duration is 500us and start with tuning request.

Transmitter Electro-Optical Characteristics

Parameter	Min	Typ	Max	Unit	Note
Laser Type	O-Band				
Operating Bit Rate	-	9.95	11.3	Gbps	9.95328 Gbit/s
Wavelength Band	1260	-	1280	nm	G.9807.1
Side Mode Suppression Ratio	30	-	-	dB	
Output Power	4	-	9	dBm	
Extinction Ratio	4	4.6	6	dB	

Receiver Electro-Optical Characteristics

Parameter	Min	Typ	Max	Unit	Note
Receiver Type	APD/TIA Receiver				
Operating Bit Rate	-	-	10	Gbps	9.95328 Gbit/s
Wavelength Band	1575	-	1580	nm	
Bandwidth (-3dB)	-	-	12	GHz	
APD Responsivity	0.6	0.75	-	A/W	CW, M=1, $\lambda = 1577$ nm
APD Damage Power	-	-	-5	dBm	
Sensitivity	-28	-29	-	dBm	BER: 1×10^{-3} @ 10 Gbps EML source ER > 8.2 dB

Case Outline and Dimensions

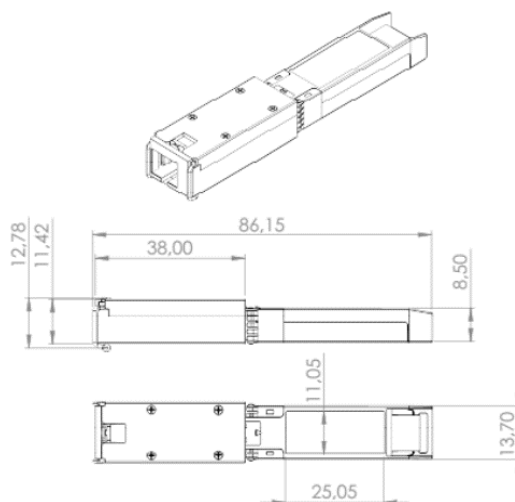

Laser Safety

This product complies with 21 CFR 1040.10 and 1040.11 except for deviations pursuant to laser notice nr. 50, dated June 24, 2007.

All versions of this product are a Class 1 laser product, tested according to IEC 60825-1:2014.

Caution – Use of controls or adjustments or performance of procedures other than those specified herein may result in hazardous radiation exposure.

**CLASS 1
LASER PRODUCT**